

# Jam Guard

GPS Anti-Jamming Solution

Senior Design Project Proposal  
Osvaldo Ramirez, Antonino Balistreri, Nima Partovi  
Sonoma State University  
Department of Engineering and Computer Science  
Advisor: Dr. Mohamed Salem  
5 December 2025

[ramireztheo@sonoma.edu](mailto:ramireztheo@sonoma.edu)  
[balistreri@sonoma.edu](mailto:balistreri@sonoma.edu)  
[partovin@sonoma.edu](mailto:partovin@sonoma.edu)

- Background
- Modern Examples of Jamming
- Problem Statement
- Existing and Proposed Solution
- Simulation
- Marketing and Engineering Requirements
- Challenges and Risks
- Goals
- Next Steps

- Global Navigation Satellite System (GNSS) was developed by the military in the 1970's with the first satellite launched in 1978
- GPS is the U.S. owned iteration with 31 Satellites, but others exist (Galileo-E.U, BeiDou-China)
- Operate on multiple frequencies L1 (1575.42 +/-7.5 MHz), L2 (1227.60 +/- 5.5 MHz), and L5 ( 1176.45 +/- 6.25MHz)



- GPS signals reach Earth at very low power levels (typically -130 dBm)
- Broadband Noise Jammers (most common) work by overwhelming a frequency range, overwhelming the signal
- While Jamming is the most common method, spoofing and meaconing are more sophisticated forms of signal disruption

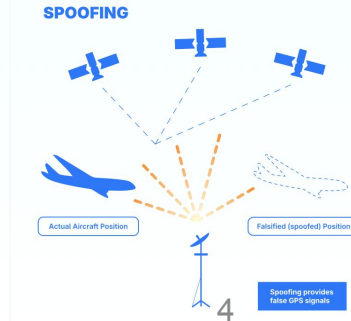



We are exploring the problem of GPS signal jamming by low-cost wideband (noise) jammers.

<b>MR1</b>	Device shall reliably detect GPS broadband jamming
<b>MR2</b>	The device must maintain usable GPS under broadband jamming
<b>MR3</b>	The device must integrate easily with existing GPS receivers
<b>MR4</b>	The device must be compact and portable
<b>MR5</b>	The device must operate efficiently on limited power <b>(9V) battery</b>
<b>MR6</b>	The device must be easy to monitor and operate

<b>ER1.1</b>	Detect jamming with $\geq 95\%$ probability at Jamming Signal Ratio $\geq 3$ dB.
<b>ER1.2</b>	Trigger jamming alert in $< 500$ ms
<b>ER2</b>	Provide $\geq 20$ dB null-forming suppression at $1,575.42$ MHz $\pm 15.34$ MHz
<b>ER3.1</b>	RF output impedance $\sim 50 \Omega \pm 10\%$ .
<b>ER3.2</b>	Support L1 ( $1,575.42$ MHz $\pm 7.5$ MHz)
<b>ER4</b>	PCB footprint $\leq 15 \times 15$ cm and weigh less than 600 g
<b>ER5</b>	Total power consumption $\leq 25$ W
<b>ER6</b>	Directional Arrow Indicator points in jam direction with 95% accuracy 8



- Tualaj 4200 Mini GPS/GNSS Anti-Jam CRPA System
  - \$ Quote required/Military Grade
- Anti-jamming device infiniDome GPSdome-SunStone – dual-band GNSS signal protection, compact design
  - \$ 2700
- Orolia GPSdome 1.02B Anti-Jammer
  - \$ Quote required- only non-ITAR



Tualaj 4200 mini



Orolia GPSdome

Google  X   

AI Mode **All** Shopping Images Videos Short videos News More Tools

Refine results **Vehicle Tracker** On sale Nearby Reviews For Sale Free Online Get

Price

- Vehicle Tracker
- Personal Safety

Price

- Under \$90
- \$90 - \$300
- \$300 - \$700
- Over \$700

Sort by

- Price: low to high
- Price: high to low

Category

- GPS Navigators
- Security Cameras
- Radio
- Signal Finders







Color

- Colors

Features

- Features

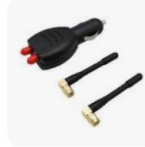
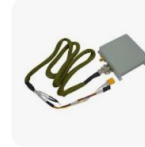
### Popular products

 <p><b>GP5000 Car Anti-Tracking GPS Blocker,...</b> \$119.99 Jammer Free delivery</p>	 <p><b>Portable Cell Phone Jammer Block...</b> \$659.99 Jammer Master</p>	 <p><b>CTL3520 Directional GPS Jammer Detecto...</b> \$2,375.00 NavtechGPS</p>	 <p><b>Gps jammers for vehicles, Gps for vehicles, Red...</b> \$17.63 Temu Free delivery on \$30+</p>
 <p><b>Suitcase Style Signal Jammer Block...</b> \$2,659.99 Jammer Master</p>	 <p><b>DIXSG Car Usb Gps Signal Interference...</b> \$28.69 neweggbusiness...</p>	 <p><b>65dB Anti-Jamming GPS</b> \$358.00 OzRobotics.com Free delivery</p>	 <p><b>Desktop All-in-One Signal Jammer Block F...</b> \$899.00 Jammer Master</p>



Jammer



**GP5000 Car Anti-Tracking GPS Blocker, Navigation jammer**  
Images may be subject to copyright. Learn more

Typically \$120

**Jammer** \$119.99  
GP5000 Car Anti-Tracking GPS Blocker, Navigation jammer  
In stock online  
Free delivery · 14-day returns

About this product

Brand Jammer

## **Spatial filtering**

- Spatial filtering uses multiple elements(antennas) and emphasizes phase control to separate signals based on the direction they come from
- Beamforming directs antenna gain toward GPS signals
- Null-Steering suppresses interference by creating nulls toward the direction of a jammer

## **Temporal filtering**

- Temporal filtering process a signal based off time or frequency of the signal

## **Pre/Post Correlation**

- pre-correlation filtering removes broadband noise and interference from a signal
- post-correlation filtering enhances signal quality by removing jamming effects and any residual noise

- Replace the current antenna on a GPS system with Jam Guard
- Integrate a null forming system into the system to block/reduce jammer signal before getting to the GPS receiver

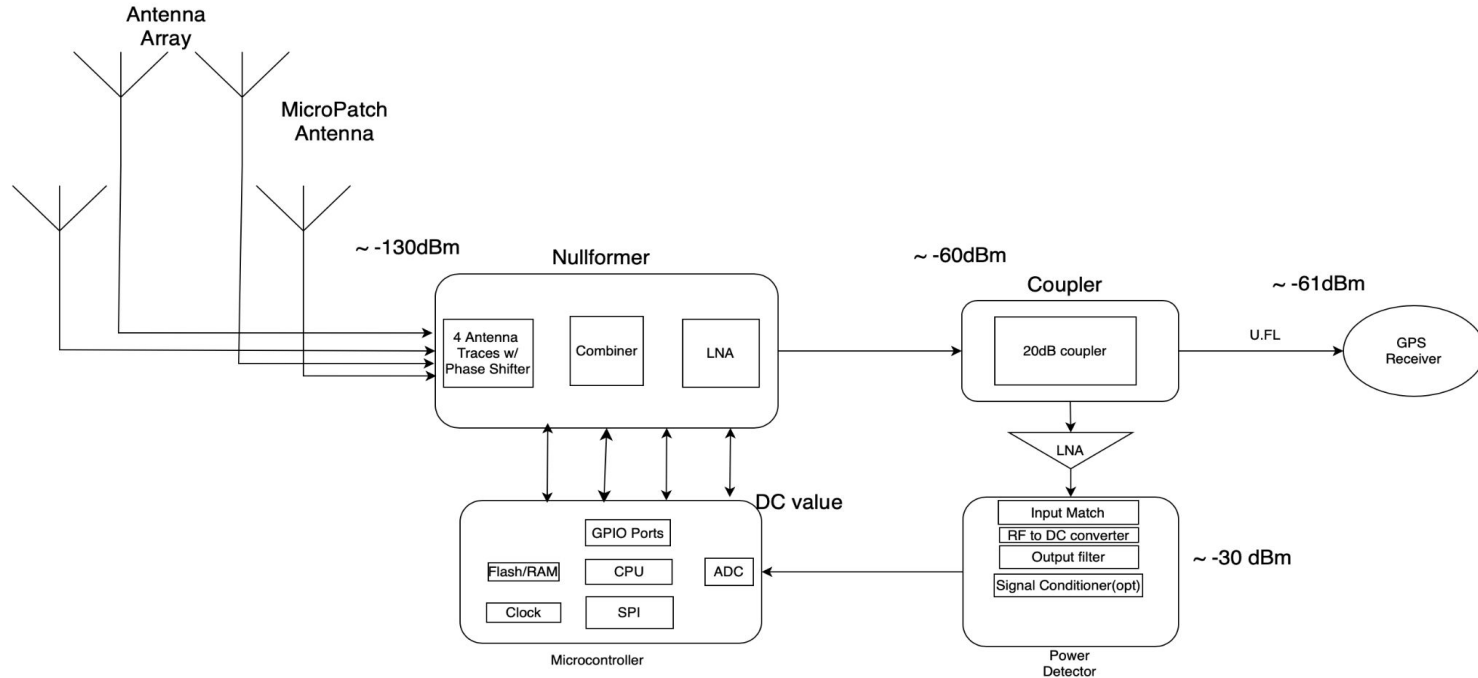

## Phased Antenna Array

- Electronic Antenna Array movement through Phase Shifter
- Changes lobe size/direction based off Phase and Magnitude
- Elements Separated by  $.5\lambda$  (Standard) to prevent grating lobes

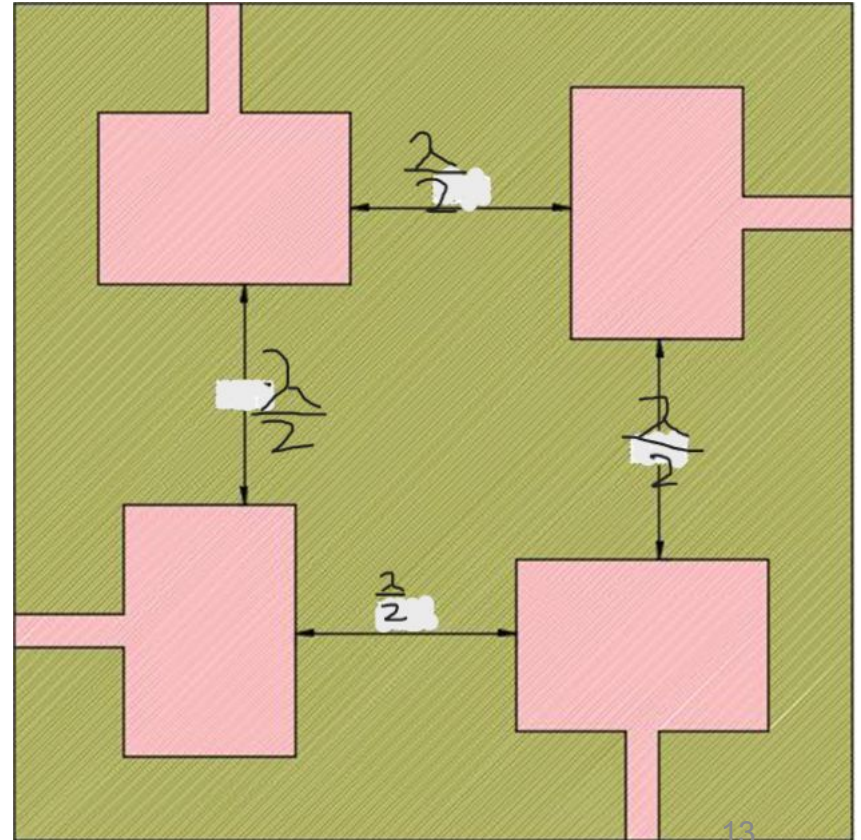

- Antenna Array:  $2 \times 2 \cdot 0.5 \lambda$  (9.525 cm)
- Nullformer: Creates the Phase Shift to direct our null
- Splitter: Used to sample minimal power from system and sending it to the detector

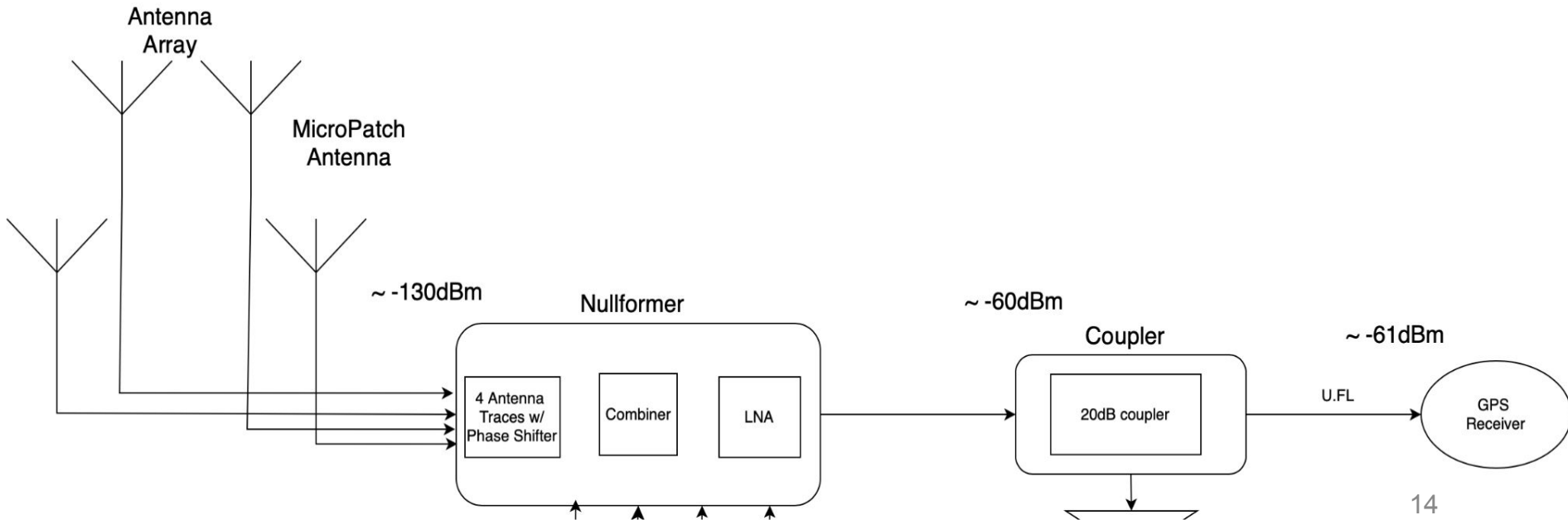

- Power Detector: Converts power level detected to DC value
- Microcontroller: Reads Value and can change phase values in the nullformer

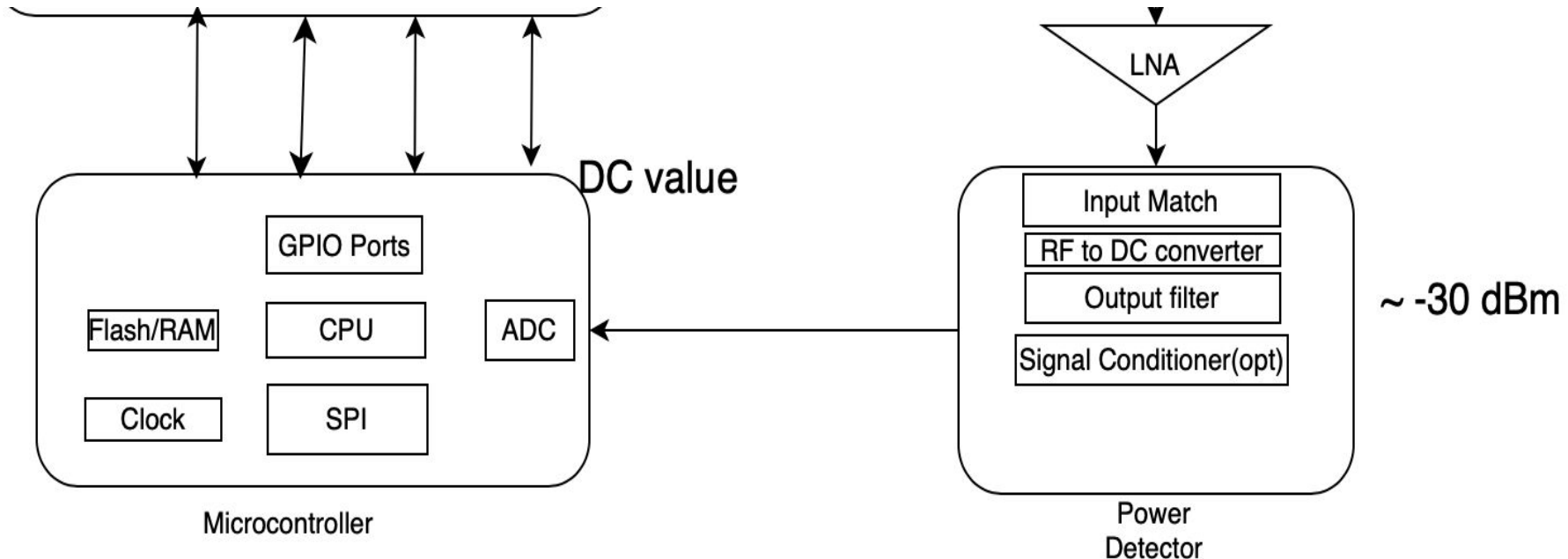

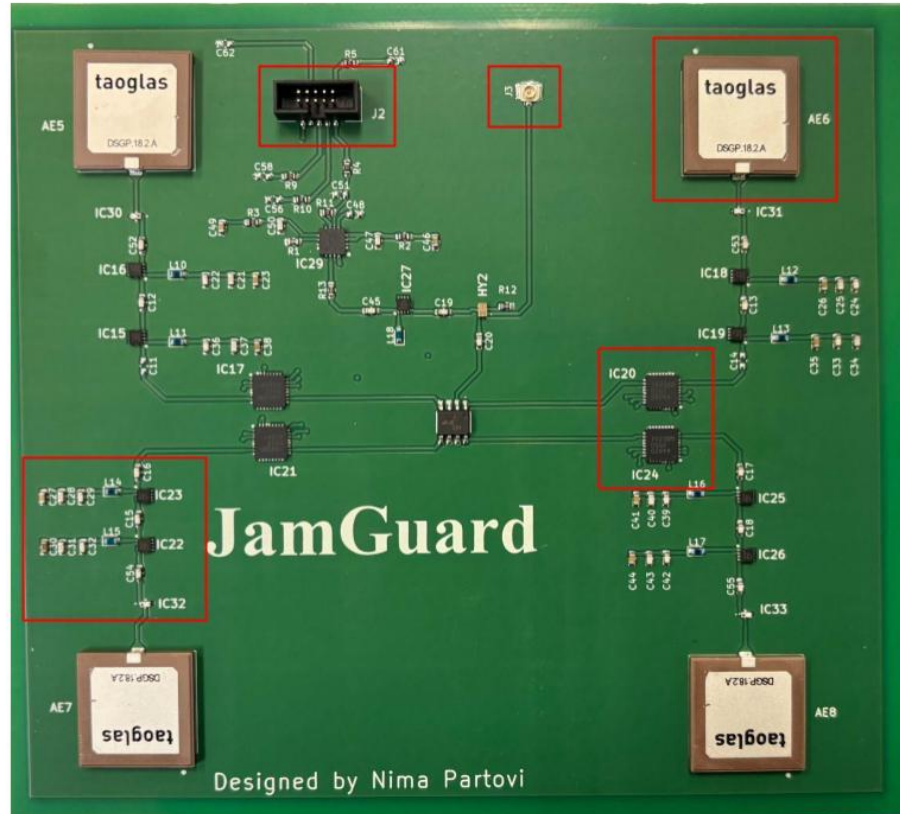

- **Visualize 2D & 3D antenna array radiation patterns before building hardware**
  - Helps us see beam shape, null direction, and interference suppression
- **Experiment safely with array geometry, phase shifts, and null-steering algorithm**
  - Zero hardware cost or risk
- **Predict how jamming affects the antenna pattern**
  - Show how jammer energy distorts the main lobe and how nulling fixes it
- **Validate algorithm performance (null depth, null width, angle error)**
  - Simulation lets us measure performance in controlled environments
- **Build lookup tables (codebooks) for real-time null steering**
  - Hardware will rely on these precomputed phase combinations

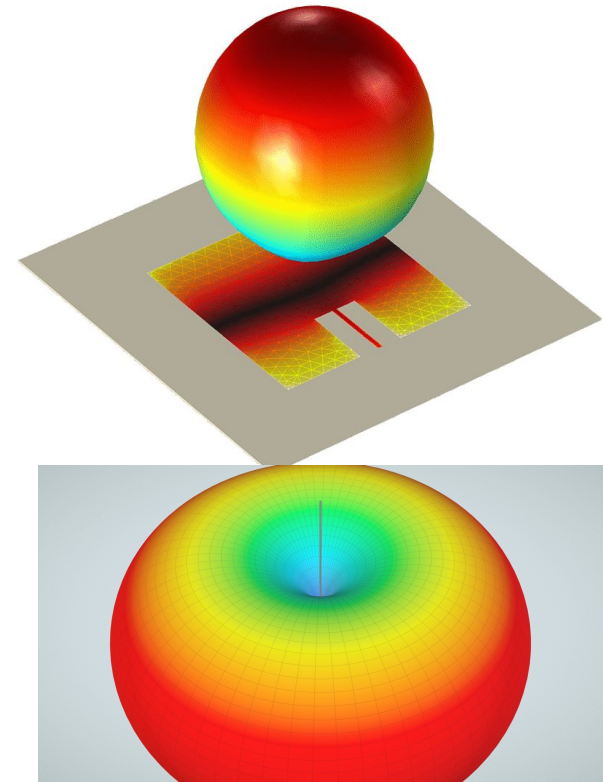

- Implemented **1D azimuth pattern only** (simple linear array assumption)
- Established understanding of array factor, phase shifts, and constructive/destructive interference
- No support for 2D element layouts or 3D visualization
- Served as a theoretical baseline that allowed us to understand fundamental null steering concepts

**Takeaway:**

V1 let us confirm the math before investing time in complex geometry or real-time search methods.

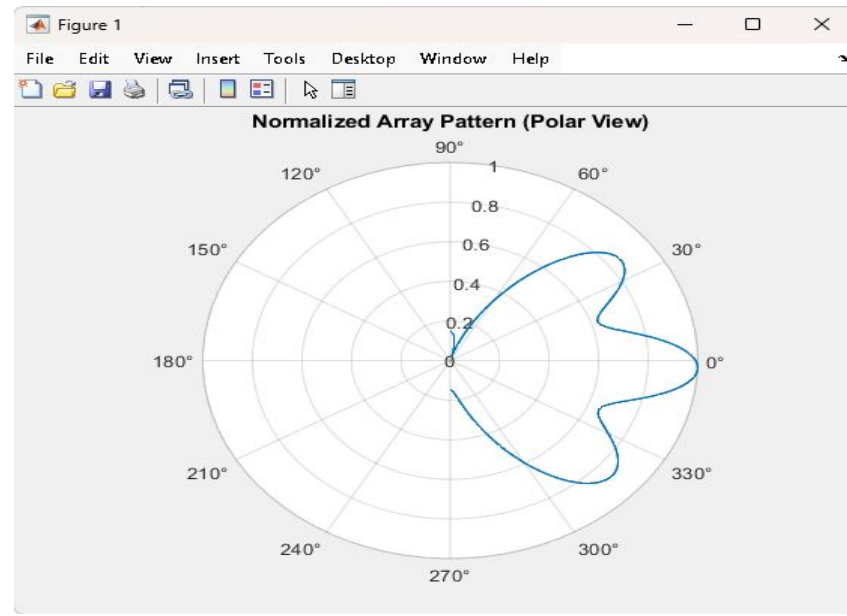

- Added **2D element layout support (2×2 array model)**
- Implemented **3D radiation pattern visualization** for accurate spatial behavior
- Demonstrated **null formation before vs after** applying computed phase shifts
- Added **beamforming scan** to detect jammer angle by sweeping beam direction
- identified key limitation:
  - Beam forming is **too slow for real-time** jamming scenarios

### Takeaway:

V2 revealed the need for a **fast, discrete lookup-table approach** instead of continuous scanning.

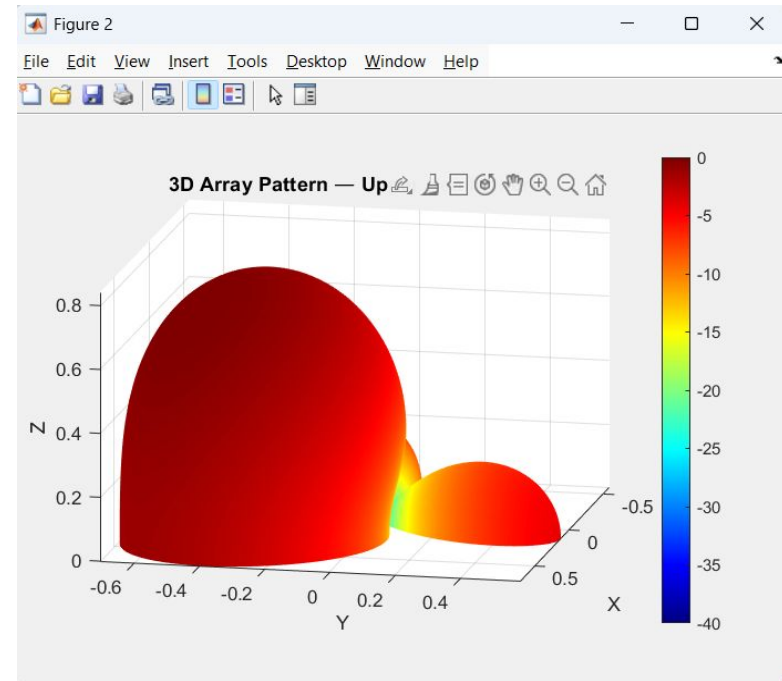

## Algorithm Development — From Theory to Practical Implementation

### 1. Beamforming & Null Steering Research

- Implemented phase-only null steering:

$$\Delta\phi = (2\pi/\lambda) \cdot d \cdot \sin(\theta_{\text{jammer}})$$

### 2. Null Depth & Null Width Experiments

- Explored how phase shifter resolution (5° steps) affects achievable null depth
- Verified relationship between array depth and null width

### 3. Identified Limitations of Scan-Based Approaches

- Continuous angle sweep is not feasible in real time

### 4. Transitioned to Codebook-Based Null Steering

- Precomputed phase combinations for every 5° × 5° angular region
- Enables fast jammer direction estimation and null steering

- **Implemented full 2D array simulation with 3D pattern visualization**
- **Built  $5^\circ \times 5^\circ$  lookup-table (codebook) for fast null steering**
  - Each entry stores phase settings for a specific jammer direction
- **Demonstrated before-and-after null patterns using codebook**

Achieved strong jammer suppression with phase-only control
- **Realistic constraints applied:**
  - Phase shifter step size
  - Array spacing ( $0.5\lambda$ )
  - Expected null width based on resolution

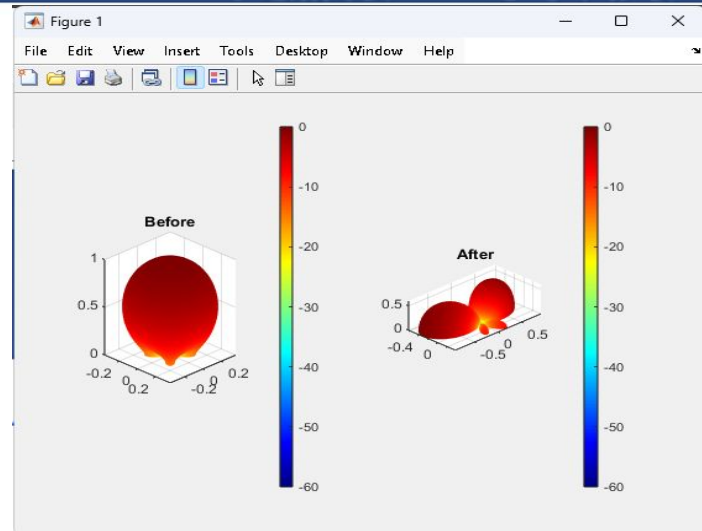

1. Researching Jamming and Nullification
2. Developing Search Algorithm
3. Selecting hardware (phase shifters, power detectors, splitters, etc)
4. Hardware cost/availability/delivery
5. Implementing PCB Evaluation Boards
6. Developing and performing tests

Likelihood → Consequences ↓	Rare (1)	Unlikely (2)	Possible (3)	Likely (4)	Certain (5)
Catastrophic (5)	Jamming Test damages Hardware (5)	Complete PCB Failure (10)	Testing Environment Unavailable (15)	Specific RF Hardware Unavailable (20)	System Requires Multiple Iterations Beyond Available Time (25)
Major (4)	Algorithm Produces Unstable Outputs (4)	RF Interference Degrades Testing Results (8)	Algorithm Failure (12)	PCB Fabrication Issues (16)	Multiple Debug Phases Slow Integration (20)
Moderate (3)	Soldering Components Onto PCB (3)	Incompatibility between software and hardware (6)	Learning RF Measurement Tools (9)	Continued Algorithm Development (12)	Calibration Drift Over Time (15)
Minor (2)	Hardware Wear and Tear (2)	Tooling or Scripting Errors (4)	Substitute Components (6)	Setting Up Testing Plans (8)	More Testing Than Anticipated (10)
Negligible (1)	Formatting Issues (1)	Communication Issues in Group (2)	Project Organization (3)	Meetings With Advisors (4)	Time Spent Testing (5)

## **Finalize system architecture and component selection**

Further develop system block diagrams and choose hardware for use based on the scope of this project. Group candidate parts to complete alternate design matrices for major components.

## **Further develop simulation and search algorithm**

Continue simulating Jam Guard using MATLAB to better understand antenna array patterns. Continue to develop search algorithm from null-steering and lookup table approach. Develop software flowcharts.

## **Build risk analysis and mitigation plans**

Consider risks and possible challenges. Develop proper contingency plans to enact when challenges arise.

11/2025 - 01/2026

- Develop PCB design boards for hardware testing
- Hardware analysis and decision making
- Algorithm development and simulation testing

02/2026 - 03/2026

- Field testing and data collection

TASK TITLE	START DATE	DUE DATE	EST. DAYS	SEP				OCT				NOV				1
				Week				Week				Week				
				1	2	3	4	1	2	3	4	1	2	3	4	
1 Project Research and Simulation																
1.1 Initial Research	9/15/25	10/7/25	22													
1.2 Project Selection	10/7/25	10/7/25	5													
1.3 Deeper RF research	10/7/25	Open	NA													
1.4 Advisor Form 1	10/15/25	10/15/25	1													
1.4.1 High Level Block Diagram	10/15/25	11/3/25	17													
1.4.2 Initial Mat.Lab programming	10/15/25	11/3/25	17													
1.5 Customer Meeting	10/21/25	10/21/25	1													
1.6 Eval Boards Schematic creation	10/25/25	11/24/25	30													
1.7 First Department Presentation	11/19/25	11/19/25	1													
1.8 Use Suggestions for Improvements	11/19/25	12/5/25	16													
1.9 492 Final Presentation	12/5/25	12/5/25	1													

Color Legend	
Color	Status
Team	Working on
Oswaldo	Working on
Nima	Working on
Nino	Working on

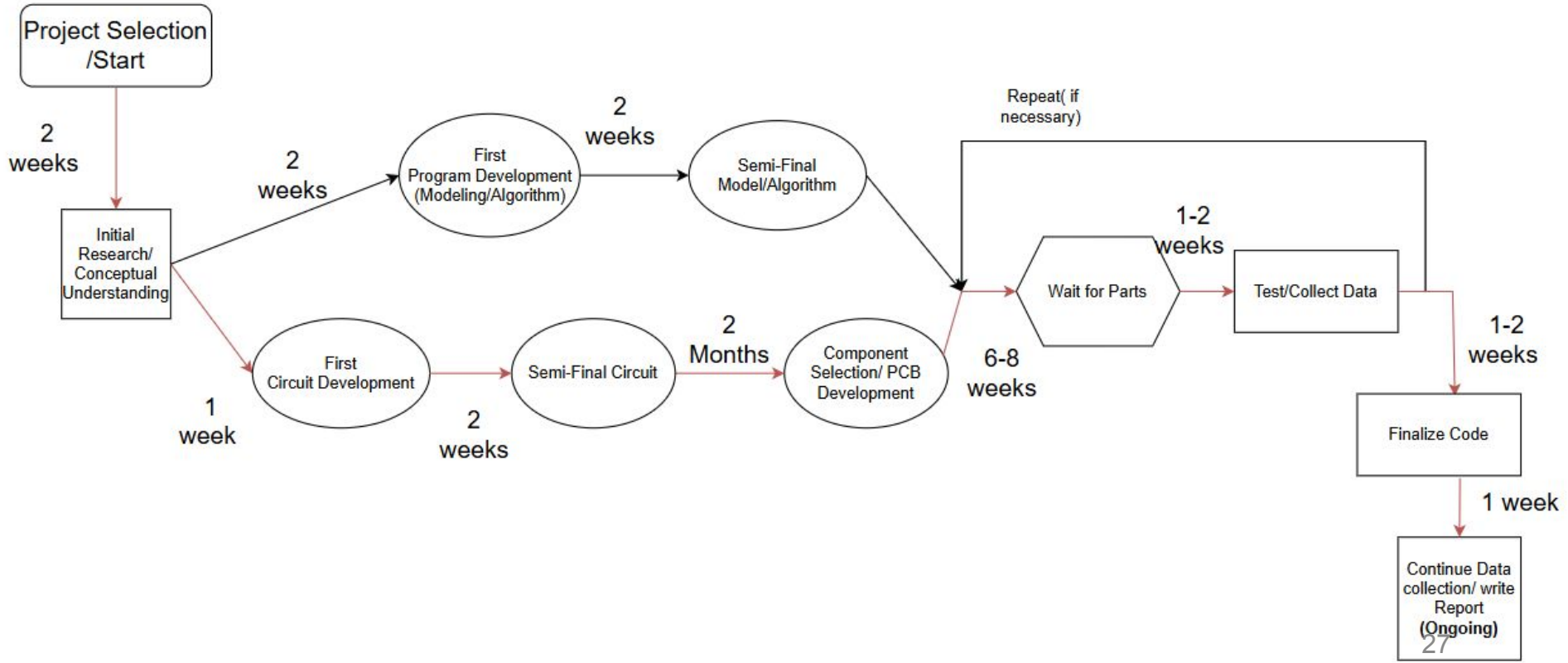

## **FT-1: Jamming Detection vs JSR (Jamming to Signal Ratio)**

Satisfies: ER1.1

Purpose: Purpose: Verify  $\geq 95\%$  detection probability at  $\text{JSR} \geq 3$  dB

Procedure:

- Connect antenna to power combiner
- Use RF source to inject artificial signal at desired power level
- Sweep “jammer” level to achieve JSR points (ex. -2, 0, +1, +3, +6, +10 dB)
- At each JSR point, run N amount of trials (~20-50). Toggle “jammer” ON, then record if jam is detected

## FT-2: Jamming Alert Latency

Satisfies: ER1.2

Purpose: Verify if alert triggers in < 500 ms

Procedure:

- Toggle jammer ON with a repeatable edge
- $\Delta t$  measurement between jammer on and LED pin ON
- GPIB

## **FT-3: Null-forming Suppression at $L1 \pm 15.34$ MHz**

Satisfies: ER2, supports MR2

Purpose: Verify  $\geq 20$  dB suppression across specified band

Procedure:

- Programmatically through microcontroller to form a null at certain value
- Scope: Measure serial signal to each phase shifter and make sure corresponds to calculations made

## **FT-4: RF Output/Input Impedance Verification**

Satisfies: ER3

Purpose: Verify  $\sim 50 \Omega \pm 10\%$  equivalent

Procedure:

- Calibrate VNA
- Measure S11 at 1575.42 MHz and across the operating band

Change to SWR after measurements\*\*

## **FT-4: RF Output/Input Impedance Verification**

Satisfies: ER3

Purpose: Verify  $\sim 50 \Omega \pm 10\%$  equivalent

Procedure:

- Calibrate VNA
- Measure S11 at 1575.42 MHz and across the operating band

Change to SWR after measurements\*\*

**FT-5: Output VSWR is less than 1.5 for L1 band**

Satisfies:

## **FT-6: PCB Footprint and Weight**

Satisfies: ER4

Purpose: Verify size  $\leq 15 \times 15$  cm and mass  $< 600$  g\*\*\*

Procedure:

- Measure length/width of board
- Weigh using a scale

## **FT-7: Total Power Consumption**

Satisfies: ER5

Purpose: Verify  $\leq 10$  W worst-case draw

Procedure:

- Identify “worst-case mode” (everything ON likely)
- Measure current at 5V

## **FT-8: Directional Arrow/LED Error in Indication**

Satisfies: ER6

Purpose: Verify defined Error rate \*\*

Procedure:

- Step in angles: 5 deg azimuth and elevation
- Identify error or no error in indication after N trials

## **ST-1: End-to-End GPS Broadband Jamming Detection**

Satisfies: MR1 & MR3

Procedure:

- GPS operating normally, turn “jammer” ON/OFF and show that jamming is detected/undetected by Jam Guard

## **ST-2: Maintain Usable GPS Under Broadband Jammin**

Satisfies: MR2

Procedure:

- Establish working GPS baseline (no jamming)
- Apply “jammer” without nulling, record performance
- Activate Jam Guard, record again

## **ST-3: 20 Hours of Operation using 9V Battery**

Satisfies: MR5

Procedure:

- Run device from 9V battery
- Record time of operation

## **ST-4: Ease of Operation**

Satisfies: MR6

Procedure:

- Recruit classmates to use device
- Record their level of satisfaction
- Score based on Jam Guard score sheet

## Output Impedance Matching

- Tested on two different boards  $31\Omega - j16.2\Omega$
- Due to unoptimal cable normalization, unable to get near  $50\Omega$  Impedance

## Code Output Results

- Using Simulation on MPXlab and via injecting a fake adc value we were able to determine the output and output response of the system

## GPS Data

- Using a RPi4 and an Adafruit V3 Gps Module we were able to determine the connectivity, number of satellites and power of the GPS signal at our location

## Power Detector Functionality

- By injecting an RF signal from an RF source into the input of the Power detector we were able to determine the functionality of the Power detector

## Antenna Array Functionalty

- Correct implementation of our Antenna Array design required soldering two 100pF capacitors onto the board



# Budget(Preliminary)

Component	Quantity	Price
Nullformer		~\$100
Phase shifter	4	\$16 per(\$64 total)
Combiner	1	~\$5
LNA	2	~\$2 per(~\$4 total)
Coupler		~\$15
Coupler	1	\$7
LNA	2	~\$2 per(~\$4 total)
Power Detector		\$6
LNA	2	~\$2 per(~\$4 total)
RF to DC	1	\$2
MicroController		\$20
ESP32	1	~\$20
GPS Receiver		\$120(already owned)
Raspberry Pi	1	\$120
PCB	1	\$60
MicroPatch Antennas	4	\$2 per (\$8 total)
<b>Total</b>		<b>~\$320</b>

## Live Demo Steps

- 1. Aim the system using the joystick**
  - a. ADC converts joystick position to Az / El
  - b. LCD displays: Az = XX°, El = YY°
- 2. Trigger jammer detection**
  - a. Button = simulated power spike
  - b. LCD shows: "Jammer detected!"
- 3. Lookup Table selects nearest angle**
  - a. computes closest Az/El bin
  - b. Retrieves 4 phase codes from CB\_PHASE\_CODE
  - c. Converts 8-bit codes to phase degrees (0–360°)
- 4. Phase settings are output**
  - a. PIC drives phase codes to ports (LATB, LATC ...)
  - b. Represents controlling 4 phase shifters
- 5. LCD displays computed phases**
  - a. View all four phases at once
  - b. OR cycle through element-by-element
  - c. Also shows binary representation of each code

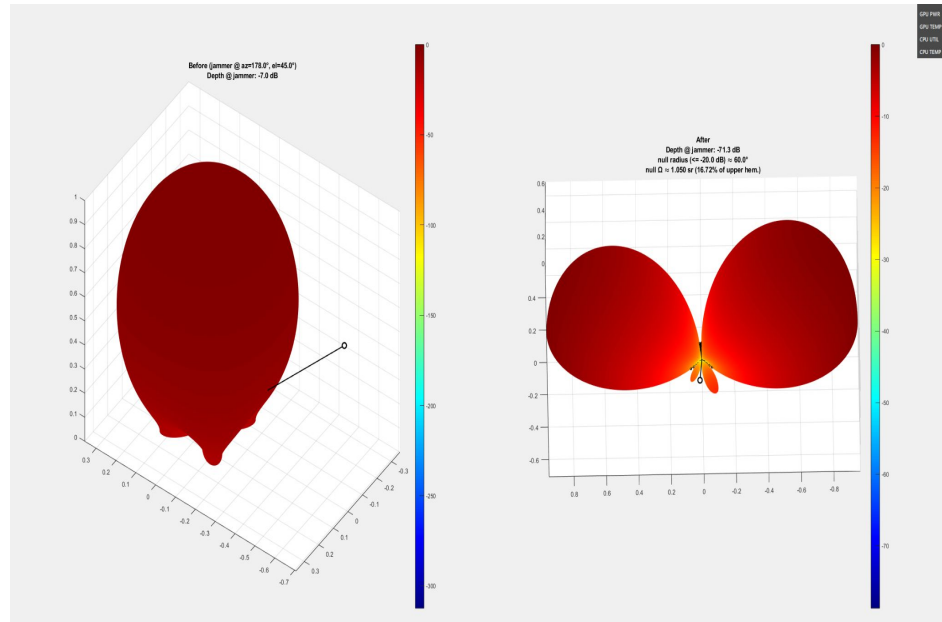

Past/Current:

EE 282 - Engineering Modeling Lab

EE 430 - Electromagnetics Theory and Applications

EE 444 - Introduction to RF Communications



# Questions/Comments

# Additional Slides

ER1.1: Insert GPS signal into Jam Guard test board, insert broadband jamming signal via combiner and adjust Jamming Signal Ratio to varying dBs and test for detection

ER1.2: Utilize same setup as ER1.1. Attach oscilloscope to GPIO pin to turn jam signal on. Measure  $\Delta t$  on the “alert” edge in multiple trials to find time of detection. Consider time for GPS lock-up: MAX 3 mins

ER2: With Nulling OFF, measure power at GPS receiver input. With Nulling ON, measure again. Calculate suppression ( $P_{\text{NoNull}} - P_{\text{Null}}$ )

ER3: Use Vector Network Analyzer (VNA) to Jam Guard RF OUT. Measure  $S_{11}$  (RF reflected) and read equivalent impedance. Low  $\approx -20$  dB, High  $\approx -3$  dB

ER4: As Jam Guard develops, try to maintain small size

ER5: Power device with 5V (all active components powered) and measure the current. Then calculate power to get “worst-case” power draw. Or alternatively use an external power measuring tool.

ER6: Implement LED states for multiple cases (jammed, clean, error, scanning, etc.) and test the cases

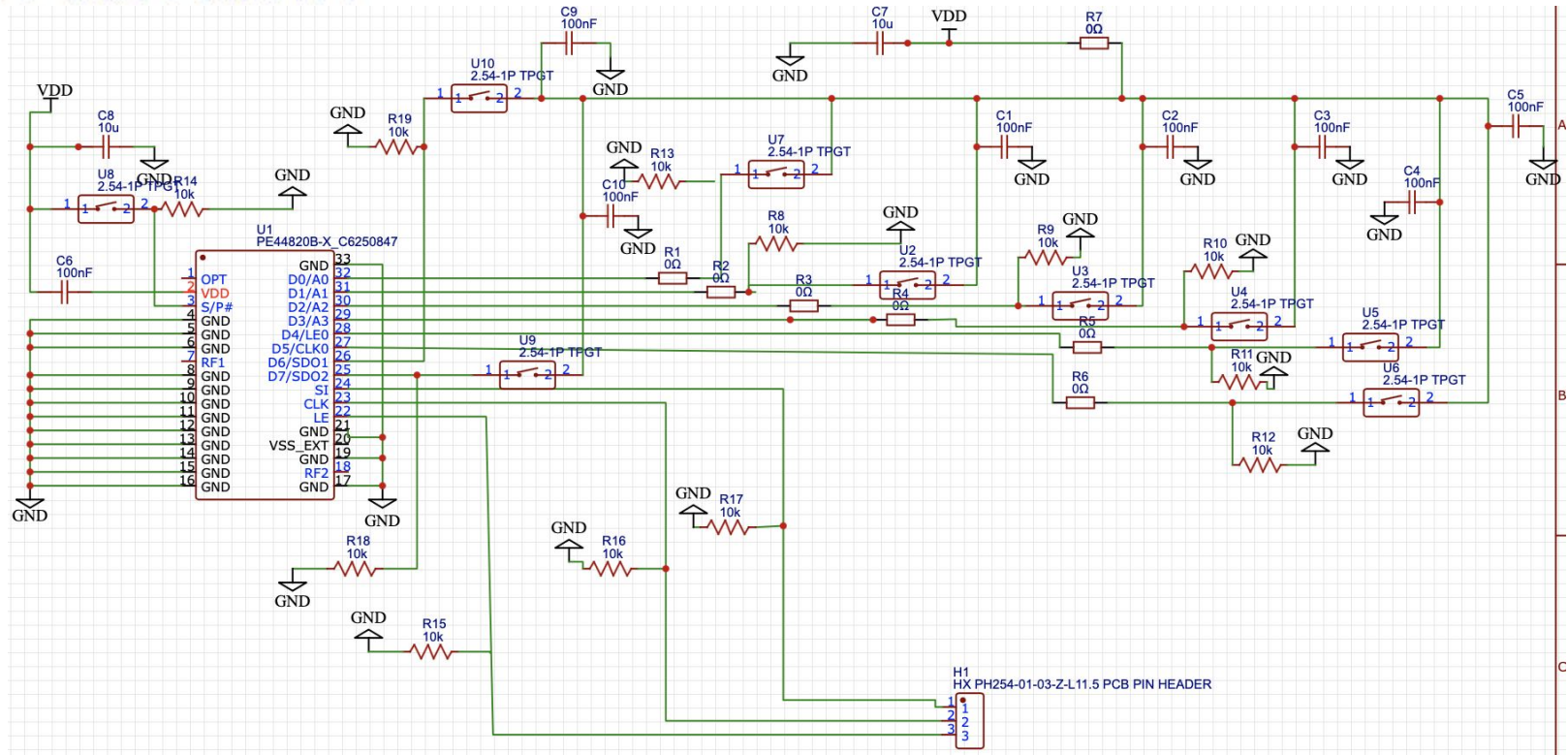

The image displays the MATLAB R2024a - student use interface. The top menu bar includes HOME, PLOTS, APPS, EDITOR, PUBLISH, and VIEW. The toolbar contains various icons for file operations (New, Open, Save, Compare, Print, Go To, Find, Bookmark), code editing (Refactor, Analyze), execution (Run, Step, Stop), and analysis (Profiler, Section Break, Run and Advance, Run to End). A notification in the top right corner states "Recording has started".

The main workspace is divided into several panes:

- Current Folder:** Shows a file explorer view of the current directory, including folders like backups, Downloads, terraria, and files like ee473proj1.m, EE Book.pdf, and Risk of Rain Returns.url.
- Editor:** Displays the code for the file ee473proj1.m. The code is as follows:

```
104 do_export = input('Export codebook to C header? (1=yes, 0=no): ');
105 if do_export
106     SCALE = 1000; % rad*scale -> int16
107     fname = 'null_codebook_5deg.h';
108     fid = fopen(fname,'w'); assert(fid>0,'fopen failed');
109     fprintf(fid, '// null_codebook_5deg.h (generated)\n#ifndef NULL_CODEBOOK_5DEG_H\n#define NULL_CODEBOOK_5DEG_H\n\n
110     fprintf(fid, 'enum { N_ELEM=%d, AZ_BINS=%d, EL_BINS=%d, CB_ROWS=%d, PH_SCALE=%d }; \n\n', N, AzBins, ElBins, CB_ROWS, PH_SCALE);
111     fprintf(fid, 'static const uint16_t CB_AZ_DEG[AZ_BINS] = { %d, AZ_DEG(1)}; \n\n';
112     for i=2:AzBins
113         fprintf(fid, ', %d', AZ_DEG(i));
114     end
115     fprintf(fid, ' }; \n\n');
```
- Command Window:** Shows the output of the code execution: "Number of elements: |".
- Workspace:** A table with columns "Name" and "Value" for variables used in the workspace.

The bottom status bar shows "Waiting for input", the system tray with weather information (57°F, Mostly cloudy), and the system clock (11:31 AM, 11/19/2025).

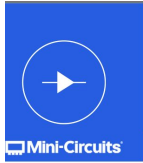

LOW NOISE, HIGH IP3

## Monolithic Amplifier PMA-545G1+

50Ω 0.4 to 2.2 GHz

### THE BIG DEAL

- High Gain, 31.5 dB typ. at 0.9 GHz
- Ultra Low Noise Figure, 0.9 dB typ. at 0.9 GHz
- High IP3, 34 dBm typ. at 0.9 GHz
- Output Power, up to +22dBm typ. at 0.9 GHz
- Single Positive Supply Voltage, 5V
- Micro-miniature size - 3mm x 3mm
- Aqueous washable
- Protected by U.S. patent no. 8,803,612

### APPLICATIONS

- Cellular
- ISM
- GSM
- WCDMA
- LTE
- GPS



Generic photo used for illustration purposes only  
CASE STYLE: DQ849

+RoHS Compliant  
The +Suffix identifies RoHS Compliance. See our web site for RoHS Compliance methodologies and qualifications

LTE Performance

## PE44820

Document Category: Product Specification

UltraCMOS® RF Digital Phase Shifter 8-bit, 1.7–2.2 GHz



### Features

- 8-bit full-range phase shifter of 358.6°; 180°, 90°, 45°, 22.5°, 11.2°, 5.6°, 2.8° and 1.4° bits
- Low RMS phase and amplitude error
  - RMS phase error of 1.0°
  - RMS amplitude error of 0.1 dB
- High linearity of +60 dBm IIP3
- Extended narrow band frequency operation of 1.1–3.0 GHz
- +105 °C operating temperature
- Packaging – 32-lead 5 × 5 × 0.85 mm QFN

### Applications

- Base station transceivers
- Weather and military radar
- Active antenna arrays

Figure 1 • PE44820 Functional Diagram

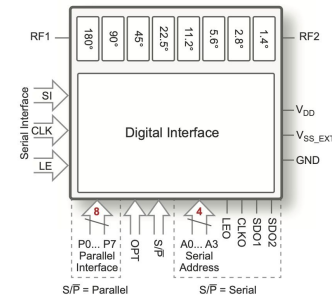

Likelihood → Consequences ↓	Rare (1)	Unlikely (2)	Possible (3)	Likely (4)	Certain (5)
Catastrophic (5)	Jamming Test damages Hardware (5)	Complete PCB Failure (10)	Testing Environment Unavailable (15)	Specific RF Hardware Unavailable (20)	System Requires Multiple Iterations Beyond Available Time (25)
Major (4)	Algorithm Produces Unstable Outputs (4)	RF Interference Degrades Testing Results (8)	Algorithm Failure (12)	PCB Fabrication Issues (16)	Multiple Debug Phases Slow Integration (20)
Moderate (3)	Soldering Components Onto PCB (3)	Incompatibility between software and hardware (6)	Learning RF Measurement Tools (9)	Continued Algorithm Development (12)	Calibration Drift Over Time (15)
Minor (2)	Hardware Wear and Tear (2)	Tooling or Scripting Errors (4)	Substitute Components (6)	Setting Up Testing Plans (8)	More Testing Than Anticipated (10)
Negligible (1)	Formatting Issues (1)	Communication Issues in Group (2)	Project Organization (3)	Meetings With Advisors (4)	Time Spent Testing (5)